

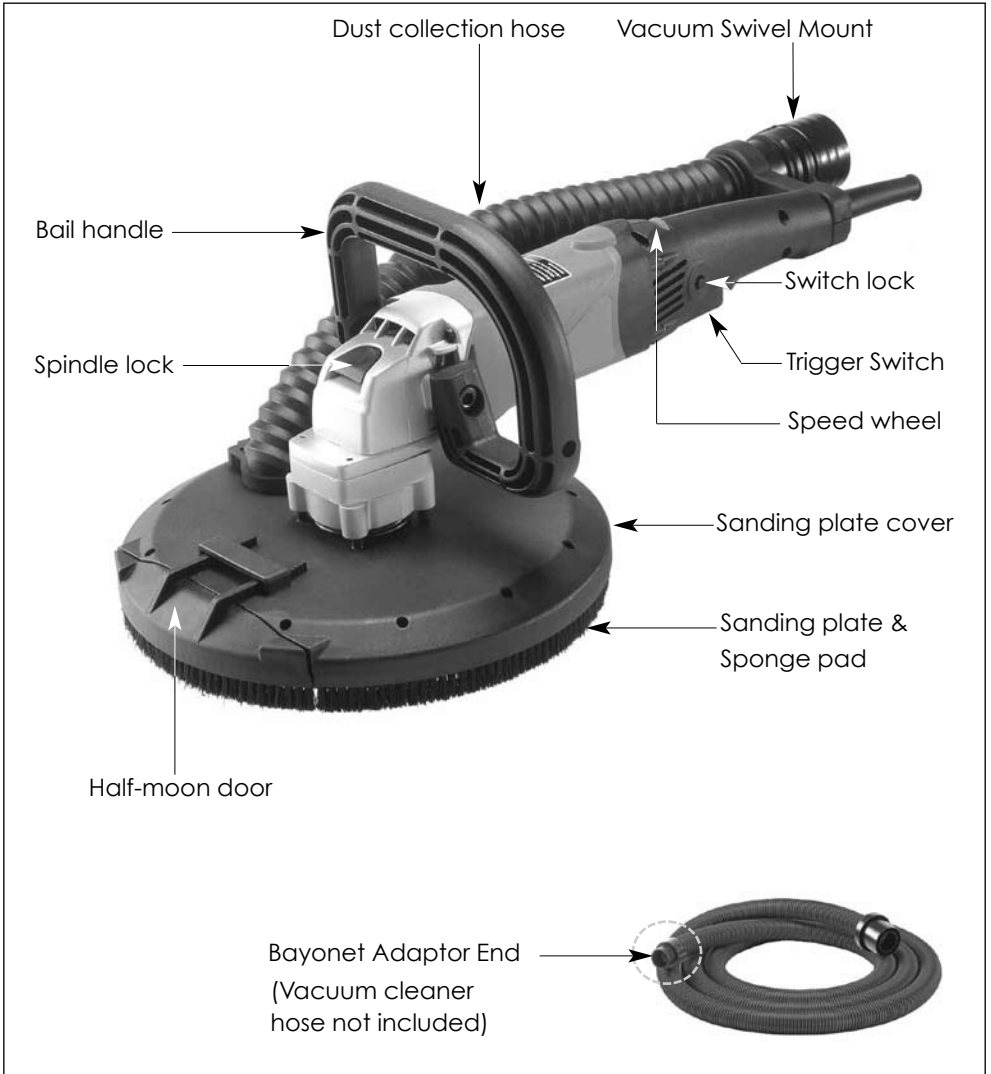

Power Hand Sander



For your personal safety, READ and UNDERSTAND before using.
SAVE THESE INSTRUCTIONS FOR FUTURE REFERENCE.



Model	PSH-1200
Power input	1200W
No load speed	650 ~ 1300/min
Sanding disc diameter	225mm
Net weight	3.16Kg

GENERAL SAFETY RULES

WARNING! Read and understand all instructions. Failure to follow all instructions listed below, may result in electric shock, fire and / or serious personal injury. The term “power tool” in all of the warnings listed below refers to your mains-operated (corded) power tool.

SAVE THESE INSTRUCTIONS.

Work area safety

Keep your work area clean and well lit. Cluttered worksites and dark areas invite accidents.

Do not operate power tools in explosive atmospheres, such as in the presence of flammable liquid, gases, or dust. Power tools create sparks which may ignite the dust or fumes.

Keep bystanders, children, and visitors away while operating a power tool. Distractions can cause you to lose control.

Electrical Safety

Grounded tools must be plugged into an outlet properly installed and grounded in accordance with all codes and ordinances. Never remove the grounding prong or modify the plug in any way. Do not use any adaptor plugs. Check with a qualified electrician if you are in doubt as to whether the outlet is properly grounded. If the tools should electrically malfunction or break down, grounding provides a low resistance path to carry electricity away from the user.

Avoid body contact with grounded surfaces such as pipes, radiators, ranges and refrigerators. There is an increased risk of electric shock if your body is grounded.

Don't expose power tools to rain or wet conditions. Water entering a power tool will increase the risk of electric shock.

Don't abuse the cord. Never use the cord to carry the tools or pull the plug from an outlet. Keep cord away from heat, oil, sharp edges or moving parts. Replace damaged cords immediately. Damaged cords increase the risk of electric shock.

When operating a power tool outside, use an outdoor extension cord marked “W-A” or “W.” These cords are rated for outdoor use and reduce the risk of electric shock.

Personal Safety

Stay alert, watch what you are doing and use common sense when operating a power tool. Do not use tool while tired or under the influence of drugs, alcohol, or medication. A moment of inattention while operating power tools may result in serious personal injury.

Use safety equipment. Always wear eye protection. Safety equipment such as dust mask, non-skid safety shoes, hard hat, or hearing protection used for appropriate conditions will reduce personal injuries.

Avoid accidental starting. Be sure switch is off before plugging in. Plugging in tools that have the switch on invites accidents.

Remove adjusting keys or switches before turning the tool on. A wrench or a key that is left attached to a rotating part of the tool may result in personal injury.

Do not overreach. Keep a proper footing and balance at all times. Proper footing and balance enables better control of the tool in unexpected situations.

Dress properly. Do not wear loose clothing or jewelry. Keep your hair, clothing and gloves away from moving parts. Loose clothes, jewelry or long hair can be caught in moving parts.

Tool use and care

Do not force tool. Use the correct tool for your application. The correct tool will do the job better and safer at the rate for which it is designed.

Do not use tool if switch does not turn it on or off. Any tool that cannot be controlled with the switch is dangerous and must be repaired.

Disconnect the plug from the power source before making any adjustments, changing accessories, or storing the tool. Such preventive safety measures reduce the risk of starting the tool accidentally.

Store idle tools out of reach of children and do not allow persons unfamiliar with the power tool or these instructions to operate the power tool. Tools are dangerous in the hands of untrained users.

Maintain tools with care. Properly maintained tools are less likely to bind and are easier to control.

Check for misalignment or binding of moving parts, breakage of parts, and any other condition that may affect the tools operation. If damaged, have the tool serviced before using. Many accidents are caused by poorly maintained tools.

Use the power tool, accessories and blades etc., in accordance with these instructions and in the manner intended for the particular type of power tool, taking into account the working conditions and the work to be performed. Use of the power tool for operations different from those intended could result in a hazardous situation.

Service

Have your tool serviced by a qualified repair person using only identical replacement parts. This will ensure that the safety of the power tool is maintained.

-WARNING- To reduce the risk of injury, user must read instruction manual.

Symbols used in this manual

V.....volts

A.....amperes

Hz.....hertz

W.....watt

~.....alternating current

n_0no load speed

/min.....revolutions or reciprocation per minute

.....class II tool

SPECIFIC SAFETY RULES

- 1 Keep hands away from rotating sanding head area at all times!**
- 2 Prolonged breathing of airborne dust from drywall sanding may effect respiratory function:**

Always use a vacuum cleaner with a bag approved for drywall dust installed.
Always wear a respirator approved for dust and mist.
- 3 Sanding LEAD-BASED paint is extremely toxic and should not be attempted.** Only allow professionals with special training and equipment perform this task.
- 4 Maintain proper footing and balance at all times.** Do not overreach. Use proper scaffolding
- 5 Always wear appropriate safety equipment when operating.**

- 6 Important: After completing sanding,** switch off the switch and wait for the coasting sanding head to stop completely before putting the tool down.
- 7 Never operate** the tool in an area with flammable solids, liquids, or gases. Sparks from the commutator/carbon brushes could cause a fire or explosion.
- 8 There are certain applications for which this tool was designed.** The manufacturer strongly recommends that this tool NOT be modified and/or used for any application other than for which it was designed. If you have any questions relative to its application DO NOT use the tool until you have contacted the manufacturer and have been advised.
- 9 Use the machine with both hands at all times.** Loss of control can cause personal injury.
- 10 Keep power supply cord clear from the working range of the machine.** Always lead the cable away behind you.
- 11 Immediately switch off the machine if unusual vibrations or if other malfunctions occur.** Check the machine in order to find out the cause.
- 12 The dust that arises when working with this tool can be harmful to health.** Use a dust absorption system and wear a suitable dust protection mask and remove deposited dust with a vacuum cleaner.

FUNCTIONAL DESCRIPTION

This Electric Drywall Sander is specially designed for the most efficient sanding of drywall or plaster walls and ceilings for both new construction and renovation work. It is designed to work in conjunction with a vacuum cleaner for minimum dust and best sanding results.

Electrical connection

The network voltage must conform to the voltage indicated on the tool name plate. Under no circumstances should the tool be used when the power supply cable is damaged. A damaged cable must be replaced immediately by an authorized Customer Service Center. Do not try to repair the damaged cable yourself. The use of damaged power cables can lead to an electric shock.

Extension cable

If an extension cable is required, it must have a sufficient cross-section so as to prevent an excessive drop in voltage or overheating. An excessive drop in voltage reduces the output and can lead to failure of the motor. The following table shows

you the correct cable diameter as a function of the cable length for this machine. Use only U.L. and CSA listed extension cables. Never use two extension cables together. Instead, use one long one.

Total Extension Cord Length (feet)	Cord Size (AWG)
25	16
50	12
100	10
150	8
200	6

● UNPACKING

Carefully remove the tool and all loose items from the shipping container. Retain all packing materials until after you have inspected and satisfactorily operated the machine.

● CARTON CONTENTS

1. Drywall Sanding Machine
2. Bayonet Adaptor End (for vacuum cleaner hose)
3. Instruction manual

DO NOT OPERATE THIS TOOL UNTIL YOU READ AND UNDERSTAND THE ENTIRE INSTRUCTION MANUAL

● To install a sandpaper disc:

- 1 Unplug the machine.
- 2 Peel away the worn out sandpaper disc, leaving the sponge backing pad in place.
- 3 Carefully center the new sandpaper disc and press into place. It will be held securely by the hook and loop backing.

● To replace the Hook and Loop Sponge Pad:

The sponge pad must be perfectly flat to get good sanding results. If it is deformed or damaged it will cause very uneven sanding. Always replace it when damaged. It is hook and loop on both sides, so to Replace it, peel it away from the hook and loop on the Sanding Plate Base and, taking great care to keep it perfectly centered, affix a new one.

● The Brush Bristles on the edge of the Sanding Plate Cover:

The brush bristles on the edge of the Sanding Plate Cover help the efficiency of the dust collection by the vacuum cleaner. These brush bristles will wear with continued use.

The Sanding Plate Cover should be replaced when the bristles are too worn to ensure effective dust collection and stabilization of the sanding head.

To replace the cover, follow these steps:

Ensure that the machine is unplugged. Press the spindle lock and rotate the sanding plate until the lock engages. Then Rotate the sanding plate counterclockwise to remove.

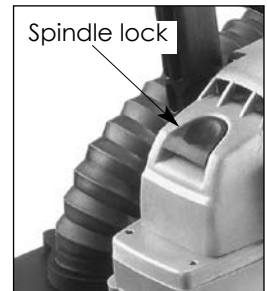

Then, press the cover down against the spring and, using snap-ring pliers, remove the circlip which holds the sanding plate cover to the gearbox.



Finally, carefully work the vacuum hose free then lift sanding plate cover away.

Replacement is the opposite of removal. **Don't forget the spring.** Entrust all repairs to an authorized service center.

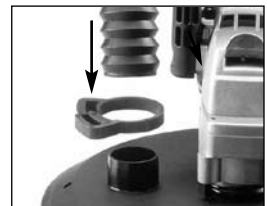

● To install the vacuum cleaner hose:

- 1 First remove the standard end from your vacuum cleaner hose (not included) then thread on the Bayonet Adaptor End (provided) to your existing vacuum cleaner hose.
- 2 Plug the Bayonet Adaptor into the swivel mount in the back of the machine. Once the tangs of the bayonet mount are fully inserted in the slots, hold the swivel mount from turning and turn the hose bayonet mount clockwise to lock.
- 3 Removal is the opposite of assembly.

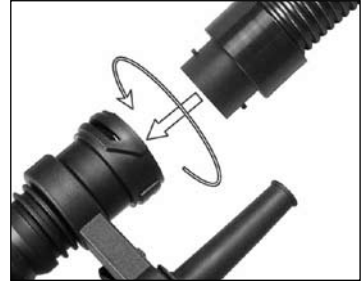

● The vacuum cleaner:

Ensure that you have a bag installed in your vacuum cleaner which is approved and rated for drywall dust.

WARNING: Failure to use an approved dust bag in your vacuum will increase the level of airborne dust in the work area. Prolonged exposure to such dust may cause respiratory harm.

● STARTING AND STOPPING TOOL

Make sure that the power circuit voltage is the same as that shown on the specification plate of the machine and that switch is "OFF" before connecting the tool to the power circuit.

● Switching the machine on and off

Squeeze the trigger switch to start the tool. Release to stop. If continuous operation is required, the switch may be locked on. To release the lock, first squeeze the trigger, then release. After the machine has been switched off, the sanding disc will still rotate for a time. Take care that parts of your body do not come into contact with the disc and do not set the machine down while it is still rotating! Anticipate and be ready for the start up torque when the machine first starts.

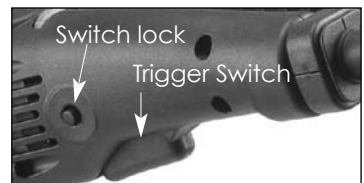

● Adjusting the rotation speed:

The speed of the machine is variable to suit different tasks. It can be adjusted from 650/min up to 1300/min by using the thumb wheel. Using the right thumb, turn to the right to increase the speed and to the left to decrease the speed.

Generally, you should use the higher speed for fast stock removal and the lower speed for more precise control.

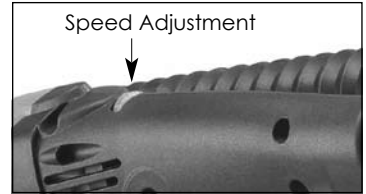

● The Half-Moon Door

The sanding plate cover is equipped with a removable half-moon door. This is to allow the operator to sand right up to the edge or into a corner.

Dust collection will not be ideal while the half-moon door is removed, so the door should only be removed when necessary and then replaced immediately.

To remove, first shut down the machine and unplug the power supply cable.

Then press the 2 tangs which retain the half-moon door just enough to release it and lift the door away. Put the door in a safe place where it will not be lost or damaged when it is time to replace it.

To replace, line up the locating pins in the sanding plate cover and snap the tangs in place.



HOW TO USE THE TOOL

Effective control of this powerful saw requires **two-handed** operation for maximum safety and control.

It is vitally important to keep stable footing at all times, especially when standing on scaffolding or stilts.

● SANDING OPERATIONS

- 1 Once the machine and vacuum cleaner are set up and all safety measures and equipment are in place, begin by turning on the vacuum cleaner and then the machine. (If you are using a vacuum cleaner with integrated switching, then simply turn the machine on.)
- 2 Begin sanding and carefully contact the work surface as lightly as possible—just enough to keep the sanding head flat against the surface.
- 3 The best technique is to use overlapping sweeps and keep the head in constant motion. Never stop too long in any one place or there will be swirl marks. With experience it will be very easy to create excellent results.

NOTE: Ensure that the sandpaper you are using is suited to the task. Overly coarse grit paper may remove material too quickly to control. While overly fine grit paper may clog too often and not shape down the surface.

CAUTION: Take care to avoid pointed projections and nails, etc. This will wipe out the sandpaper and probably damage the sponge pad as well.

MAINTENANCE

● KEEP TOOL CLEAN

Periodically blow out all air passages with dry compressed air. All plastic parts should be cleaned with a soft damp cloth. NEVER use solvents to clean plastic parts. They could possibly dissolve or otherwise damage the material.

Wear safety glasses while using compressed air.

Clean the vacuum swivel connector as too much dust will keep it from turning freely.

● THE CARBON BRUSHES

The carbon brushes are a normal wearing part and must be replaced when they reach their wear limit.

NOTE: Checking and replacing the carbon brushes should be entrusted to a qualified service center.

The carbon brushes furnished will last approximately 50 hours of running time or 10,000 on/off cycles. Replace both carbon brushes when either has less than 1/4" length of carbon remaining. To inspect or replace brushes, first unplug the machine. Remove the hose clamp, then the right and left handle halves. Remove the 2 screws to remove the electronics unit and carefully hold it off to the side. Avoid straining any of the wires. Remove each brush holder screw and brush holder in turn.

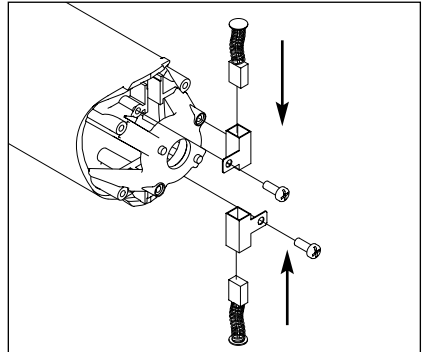
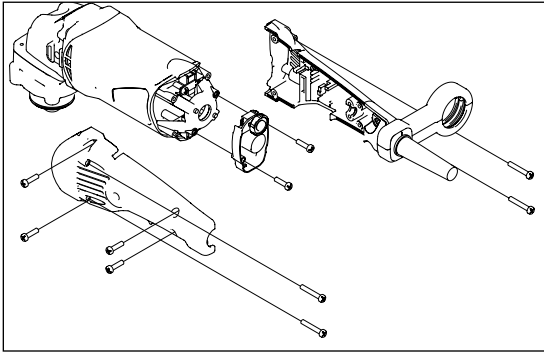

NOTE: When putting the Carbon Brushes back into the Carbon Brush Holders it is essential that both flanges go back inside the holder.

NOTE: To reinstall the same brushes, first make sure the brushes go back in the way they came out. Otherwise a break-in period will occur that will reduce motor performance and increase brush wear.

Replacing is the reverse of removal. Replace the brushes in the holders then put the holders in place in the housing and secure the screws. When Replacing the handle cover halves take great care that all wires are in place and not in a position to be pinched when it is retightened. It is recommended that, at least once a year, you take the tool to an Authorized Service Center for a thorough cleaning and lubrication.

- If the replacement of the power supply cord is necessary, this has to be done by the manufacturer or their agent in order to avoid a safety hazard.

WIRING

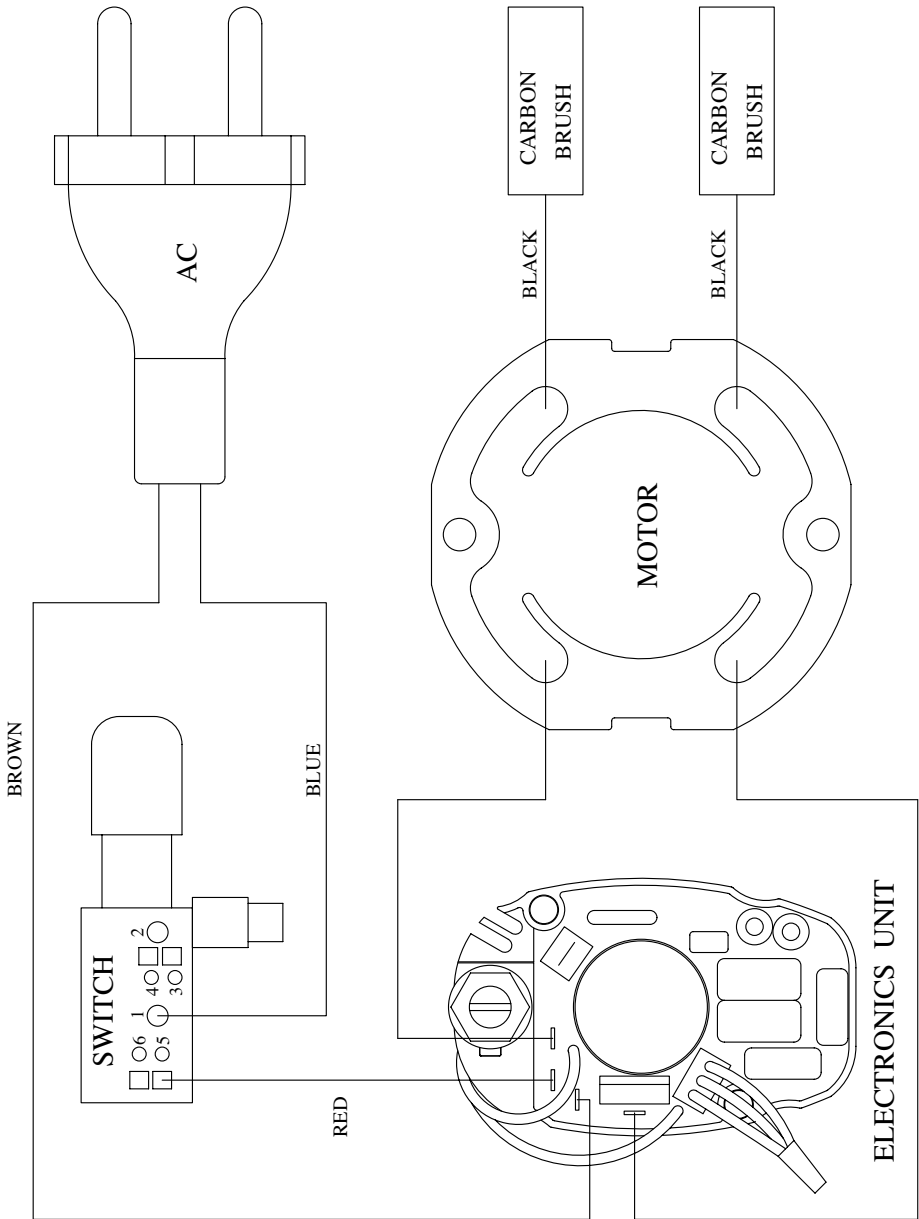

PARTS LIST

No.	Parts Name	Q'TY	No.	Parts Name	Q'TY
1	POWER SUPPLY CABLE 0.75 x 2C x 3M	1	34	PARALLEL KEY 4 x 4 x 8	1
2	CORD ARMOR	1	35	INPUT GEAR SHAFT 9T	1
3	CABLE CLIP	1	36	BALL BEARING 6001 zz	1
4	SCREW M4 x 14	6	37	GEAR PLATE	1
5	WIRE LEAD	1	38	SCREW M4 x 16	4
6	SWITCH	1	39	BUSHING 8 x 12 x 6	1
7	SCREW M4 x 25	4	40	SPINDLE GEAR 22T	1
8	RIGHT HANDLE COVER	1	41	EXTERNAL CIRCLIP S-12	1
9	LEFT HANDLE COVER	1	42	BALL BEARING 6001-2RS	1
10	SCREW M4 x 20	2	43	PARALLEL KEY 3 x 3 x 8	1
11	ELECTRONICS UNIT	1	44	SPINDLE	1
12	THUMB WHEEL	1	45	GEAR COVER	1
13	BRUSH SCREW M4 x 8	2	46	SCREW M4 x 25	4
14	CARBON BRUSH	2	47	INTERNAL CIRCLIP R-28	1
15	CARBON BRUSH HOLDER	2	48	SPRING $\varnothing 2 \times \varnothing 49 \times 40L \times 4$	1
16	SCREW M4 x 8	1	49	SANDING PLATE COVER	1
17	FLAT WASHER M4	1	50	HALF-MOON DOOR	1
18	PLASTIC WASHER $\varnothing 4 \times \varnothing 11 \times 1$	1	51	EXTERNAL CIRCLIP S-40	1
19	PICKUP MAGNET $\varnothing 8 \times \varnothing 15 \times 5$	1	52	SANDING PLATE BASE	1
20	SPACER $\varnothing 8 \times \varnothing 12 \times 10$	1	53	HOOK & LOOP SPONGE PAD	1
21	MOTOR HOUSING	1	54	SOCKET CAP SCREW M8 x 16	2
22	STATOR	1	55	BAIL HANDLE	1
23	STATOR SCREW M4 x 60	2	56	PLASTIC HOSE CLIP	1
24	BALL BEARING 608-2RS	1	57	SPRING $\varnothing 1 \times \varnothing 32 \times 363L \times 30$	1
25	ARMATURE M1.0 6T	1	58	VACCUM HOSE	1
26	BALL BEARING 6000-2RS	1	59	CLAMP PIECE-RIGHT	1
27	GEAR CASE	1	60	CLAMP PIECE-LEFT	1
28	SPINDLE LOCK BUTTON	1	61	THUMB KNOB M5 x 16	1
29	SPRING $\varnothing 0.9 \times \varnothing 10 \times 13.5L \times 4$	1	62	HOSE BRACKET-LOWER	1
30	SPINDLE LOCK	1	63	HOSE BRACKET-UPPER	1
31	SCREW M4 x 30	4	64	BAYONET SWIVEL CONNECTOR	1
32	BUSHING 6 x 10 x 8	1	65	HOSE BAYONET CONNECTOR	1
33	BEVEL GEAR M1.0 46T	1			

WARRANTY

Wallboard Tool Co Pty Ltd warrants that this product will be free from any defect in materials or workmanship for twelve (12) months from your Purchase Date (noted on your invoice or receipt).

At its discretion, Wallboard Tool Co Pty Ltd will either repair or replace your product, if it is found on inspection by Wallboard Tool Co Pty Ltd or a registered and approved Wallpro Service Agent to have any such defect.

Warranty Claim Procedure

To make a claim under this Warranty, you must:

- First contact the Wallboard Tool Co Pty Ltd distributor where you purchased the product
- Return the product to the distributor accompanied by the proof of purchase (invoice or receipt) You will be responsible for the delivery to and collection of the product from the distributor.

Warranty Application

This Warranty applies only:

1. To a product sold to you by Wallboard Tool Co Pty Ltd or by a Wallboard Tool Co Pty Ltd distributor
2. If you use the product for your private or business purposes

Warranty Exclusions

This Warranty will not apply if any of the following occurs during the relevant warranty period:

1. The product is serviced or repaired by anyone other than by a registered and approved Wallpro service agent
2. You use a Product contrary to the technical or operating environment guidelines recommended in its user guide or manual;
3. Any wear parts included in your product, (for example: including but without limitation: Velcro Foam Adaptors, Bearings, Bit Tips, Carbon Brushes, etc), reaches the end of its service life;
4. A product's malfunction or failure to perform to Wallboard Tool Co Pty Ltd specifications results from:
 1. deliberate or accidental damage; or
 2. neglect or modification; or
 3. incorrect voltage or a power surge; or
 4. use of non-genuine replacement parts or accessories.

Non-genuine Items

If you use non-genuine replacement parts in the product, you may damage the product and may invalidate this warranty.

Our goods come with guarantees that cannot be excluded under the Australian Consumer Law. You are entitled to a replacement or refund for a major failure and for compensation for any other reasonably foreseeable loss or damage. You are also entitled to have the goods repaired or replaced if the goods fail to be of acceptable quality and the failure does not amount to a major failure.

Details of the company giving this warranty:

Wallboard Tool Co Pty Ltd
30 Leda Drive, West Burleigh, Qld 4220, Australia
Phone: +61 7 5535 7655. Email: info@wbtc.com.au

The Wallboard Tools and Wallpro names as well as the Wallboard Tools and Wallpro Trade Tools logos are registered Trade Marks of Wallboard Tool Co Pty Ltd



WallproTM
TRADE TOOLS

CUSTOMER SERVICE

1300 653 177